

## Dual Channel Transmissive Optical Sensor with Phototransistor Output

### Description

This device has a compact construction where the emitting light sources and the detectors are located face to face on the same optical axes. The operating wavelength is 950 nm. The detectors consists of phototransistors. Distance of both channels is 2.66 mm.

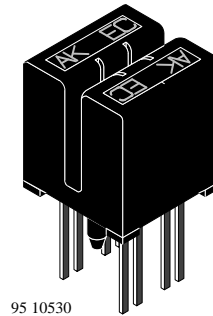

### Applications

- Accurate position sensor for shaft encoder
- Detection of opaque material like paper, IBM cards, magnetic tapes etc.
- Detection of motion direction

### Features

- Gap 1.5 mm
- Package height: 10 mm
- Plastic polycarbonate housing
- Aperture 0.2 mm for both channels

### Pin Connection

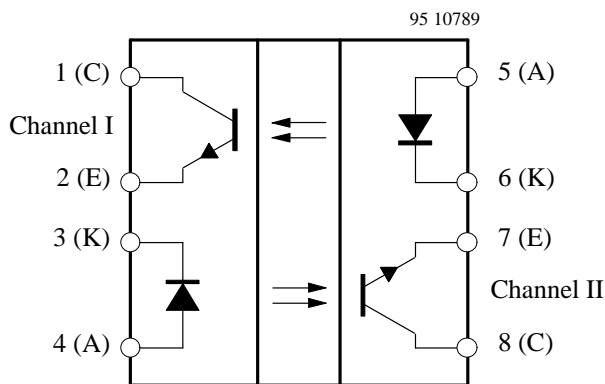

Note: Thermal dot indicates channel 1

## Absolute Maximum Ratings

### Input (Emitter)

Parameters	Test Conditions	Symbol	Value	Unit
Reserve voltage		$V_R$	5	V
Forward current		$I_F$	50	mA
Forward surge current	$t_p \leq 10 \mu s$	$I_{FSM}$	3	A
Power dissipation	$T_{amb} \leq 25^\circ C$	$P_v$	100	mW
Junction temperature		$T_j$	100	$^\circ C$

### Output (Detector)

Parameters	Test Conditions	Symbol	Value	Unit
Collector emitter voltage		$V_{CEO}$	70	V
Emitter collector voltage		$V_{ECO}$	7	V
Collector current		$I_C$	50	mA
Power dissipation	$T_{amb} \leq 25^\circ C$	$P_v$	100	mW
Junction temperature		$T_j$	100	$^\circ C$

### Coupler

Parameters	Test Conditions	Symbol	Value	Unit
Total power dissipation	$T_{amb} \leq 25^\circ C$	$P_{tot}$	200	mW
Operation temperature range		$T_{amb}$	-25 to +85	$^\circ C$
Storage temperature range		$T_{stg}$	-25 to +100	$^\circ C$
Soldering temperature	2 mm from case, $t \leq 5 s$	$T_{sd}$	260	$^\circ C$

## Electrical Characteristics

$T_{amb} = 25^{\circ}\text{C}$

### Input (Emitter)

Parameters	Test Conditions	Symbol	Min.	Typ.	Max.	Unit
Forward voltage	$I_F = 30 \text{ mA}$	$V_F$		1.20	1.3	V
Breakdown voltage	$I_R = 100 \text{ }\mu\text{A}$	$V_{(BR)}$	5			V
Junction capacitance	$V_R = 0, f = 1 \text{ MHz}$	$C_j$		50		pF

### Output (Detector)

Parameters	Test Conditions	Symbol	Min.	Typ.	Max.	Unit
Collector emitter voltage	$I_C = 1 \text{ mA}$	$V_{CEO}$	70			V
Emitter collector voltage	$I_E = 100 \text{ }\mu\text{A}$	$V_{ECO}$	7			V
Collector dark current	$V_{CE} = 25 \text{ V}, I_F = 0, E = 0$	$I_{CEO}$		10	200	nA

### Coupler

Parameters	Test Conditions	Symbol	Min.	Typ.	Max.	Unit
Collector current per channel	$V_{CE} = 10 \text{ V}, I_F = 30 \text{ mA}$	$I_C$	400		1000	$\mu\text{A}$
Collector emitter saturation voltage	$I_F = 30 \text{ mA}, I_C = 0.1 \text{ mA}$	$V_{CEsat}$			0.2	V
Crosstalk	$I_{F1} = 0, I_{F2} = 30 \text{ mA}, V_{CE} = 10 \text{ V}$	$I_{CX1}$			15	$\mu\text{A}$
	$I_{F1} = 30 \text{ mA}, I_{F2} = 0, V_{CE} = 10 \text{ V}$	$I_{CX2}$			15	$\mu\text{A}$
Phase angle	see test circuit	Phi		90		$^{\circ}$

### Test Circuit

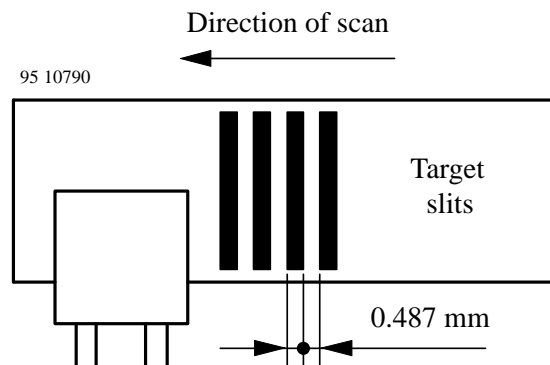

Figure 1. Phase angle measurement

## Ozone Depleting Substances Policy Statement

It is the policy of **TEMIC TELEFUNKEN microelectronic GmbH** to

1. Meet all present and future national and international statutory requirements.
2. Regularly and continuously improve the performance of our products, processes, distribution and operating systems with respect to their impact on the health and safety of our employees and the public, as well as their impact on the environment.

It is particular concern to control or eliminate releases of those substances into the atmosphere which are known as ozone depleting substances (ODSs).

The Montreal Protocol (1987) and its London Amendments (1990) intend to severely restrict the use of ODSs and forbid their use within the next ten years. Various national and international initiatives are pressing for an earlier ban on these substances.

**TEMIC TELEFUNKEN microelectronic GmbH** semiconductor division has been able to use its policy of continuous improvements to eliminate the use of ODSs listed in the following documents.

1. Annex A, B and list of transitional substances of the Montreal Protocol and the London Amendments respectively
2. Class I and II ozone depleting substances in the Clean Air Act Amendments of 1990 by the Environmental Protection Agency (EPA) in the USA
3. Council Decision 88/540/EEC and 91/690/EEC Annex A, B and C (transitional substances) respectively.

**TEMIC** can certify that our semiconductors are not manufactured with ozone depleting substances and do not contain such substances.

**We reserve the right to make changes to improve technical design and may do so without further notice.**

Parameters can vary in different applications. All operating parameters must be validated for each customer application by the customer. Should the buyer use TEMIC products for any unintended or unauthorized application, the buyer shall indemnify TEMIC against all claims, costs, damages, and expenses, arising out of, directly or indirectly, any claim of personal damage, injury or death associated with such unintended or unauthorized use.

TEMIC TELEFUNKEN microelectronic GmbH, P.O.B. 3535, D-74025 Heilbronn, Germany  
Telephone: 49 (0)7131 67 2831, Fax number: 49 (0)7131 67 2423